

Cat. ID No. 1000688

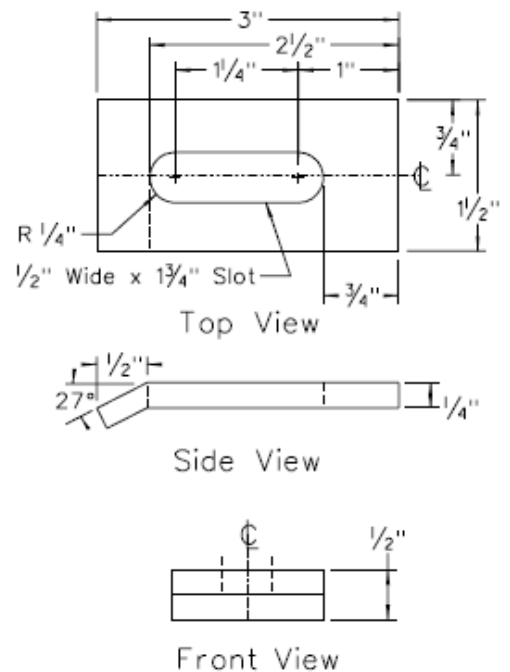

Cat. ID No. 1000689

1. Scope

This specification applies to hold down cleats used to secure padmounted equipment to vaults and pads.

2. Material ID Numbers

This specification applies to the following District Material ID Numbers: **1000688** & **1000689**

3. Reference Standards

Except as modified herein, the cleats shall meet the applicable requirements of the latest revisions of ANSI C37.42, C135.1 and ASTM A-153.

4. Physical Characteristics

Hold down cleats shall be dimensioned per the drawings above. Minor variations in dimensions and design may be acceptable with prior District approval.

5. Construction

Hold down cleats shall be manufactured from carbon steel and shall be free of sharp edges, burrs, cracks and other imperfections. Cleats shall be hot dip galvanized in accordance with ASTM A-153.

6. Packaging

Cleats shall be packaged in heavy duty boxes in quantities of 50 per box.